

# User Manual



## G-MAX SERIES

In order to prevent improper operation before use, please carefully read this manual.

# Table of Contents

1. Manual Description .....	1
1.1 Scope of application .....	1
1.2 Target audience .....	1
1.3 Symbol usage .....	1
1.4 Explanation of symbols .....	1
2. Safety Instructions .....	2
2.1 Fair Use .....	2
3. Product description .....	3
3.1 Basic features .....	3
3.2 Product Principle .....	4
3.3 Operating mode .....	4
3.4 EMS control mode .....	4
3.5 Energy management mode .....	5
3.5.1 Constant power charge and discharge .....	5
3.5.2 Peak shaving and valley filling .....	5
3.5.3 Demand control .....	5
3.5.4 Anti-backflow control .....	5
3.6 Product size .....	6
3.7 System technical parameters .....	7
3.8 Component Description .....	8
3.9 Panel Introduction .....	9
4. Unpacking and handling .....	9
4.1 Check after unpacking .....	9
4.2 Unpacking precautions .....	10
4.3 storage .....	10
4.4 transportation .....	10
4.4.1 Forklift transportation .....	10
4.4.2 Crane handling .....	11
4.5 Transportation before unpacking .....	11
4.5.1 Transportation method .....	11
4.5.2 Forklift handling steps .....	11
4.5.3 Crane handling step .....	11
4.6 Transportation after unpacking .....	13
4.6.1 Forklift transportation .....	13
4.6.2 Crane handling .....	13
5. Engineering Installation .....	14
5.1 Installation Tips .....	14

5.2 Preparation before installation .....	14
5.2.1 Installation environment requirements .....	14
5.2.2 Installation site requirements .....	15
5.3 Ground connection .....	18
6. Electrical installation .....	19
6.1 Wiring preparation .....	19
6.1.1 Cable requirements .....	19
6.1.2 Crimp end AC terminal .....	19
6.1.3 AC input wiring .....	21
6.2 G-MAX power on .....	23
6.2.1 Check before powering on .....	23
6.2.2 Power-on steps .....	23
6.3 G-MAX Shutdown .....	24
6.3.1 Normal shutdown .....	24
6.3.2 Shutdown in case of malfunction or emergency .....	24
7. Daily care and maintenance .....	26
7.1 Daily inspection items .....	27
7.2 Regular inspection items .....	28
7.3 Liquid Cooler Maintenance Work .....	28
7.4 Other maintenance projects .....	30
7.5 System cleaning .....	31
7.6 Touch-up operation instructions .....	31

# 1. Manual Description

## 1.1 Scope of application

This manual applies to the following types of industrial and commercial energy storage products for fixing, installation, commissioning, maintenance and troubleshooting methods.

GM215kWh-100kW-2h





## 1.2 Target audience

This manual is for use only by electricians with electrical operation certificates. The operations described in the manual must be performed by trained and experienced electricians in accordance with basic electrical safety protection requirements.

Note: Maintenance personnel must hold a qualified electrician certificate issued by the Safety Supervision Bureau or a Maitian Energy after-sales maintenance engineer to carry out maintenance work.



## 1.3 Symbol usage





The following are safety instructions and general information symbols that may be used in this manual.

	<b>Danger</b>
<b>Danger!</b> "DANGER" indicates a highly hazardous situation which, if not avoided, will result in death or serious injury.	
	<b>warn</b>
<b>warn!</b> WARNING indicates a moderately hazardous situation which, if not avoided, could result in death or serious injury.	
	<b>careful</b>
<b>careful!</b> CAUTION indicates a less hazardous situation which, if not avoided, may result in minor or moderate injury.	
	<b>Notice</b>
<b>Notice!</b> CAUTION provides important tips and instructions which, if not avoided, could result in property damage.	

## 1.4 Explanation of symbols

This section explains the symbols displayed on the G-MAX and its labels.

symbol	explain
	Danger from high temperatures. G-MAX will rise during operation and contact should be avoided.
	Danger due to high voltage. Due to the high voltage present in the G-MAX , there is a high potential for life-threatening hazards!
	Hazards, Warnings and Precautions Important safety information regarding personal safety. Failure to follow the safety information in this manual may result in injury or death!

	<p>Maintenance and replacement</p> <p>After powering off equipment other than battery packs, you must wait 5 minutes to ensure that the equipment is out of power before operating the equipment.</p>
	<p>Please read the manual before performing any operation on G-MAX.</p>
	<p>Product should not be disposed of as household waste.</p>
	<p>PE protective ground terminal.</p>

## 2. Safety Instructions

### 2.1 Fair Use

- G-MAX is designed and tested in accordance with international safety requirements. However, certain safety measures must be taken when installing and operating G-MAX. The installer must read and follow all instructions, precautions and warnings in this installation manual.
- All operations, including transportation, installation, startup and maintenance, must be performed by qualified and trained personnel.
- The electrical installation and maintenance of this product should be performed by a certified electrician and should comply with local standards and relevant safety regulations for electrical systems.
- Before installation, check the machine to ensure that it has no damage caused by transportation or handling that may affect the insulation performance or safety distance. Carefully select the installation location and comply with the specified cooling requirements. Unauthorized removal of necessary protective measures, improper use, and improper installation operations may cause serious safety hazards, impact hazards, or equipment damage.
- Before connecting this product to the distribution grid, please contact your local distribution grid company for approval. This connection must be made by qualified technicians.
- When operating or maintaining G-MAX, you must wear a safety helmet, insulating gloves, insulating shoes, and goggles. It is strictly prohibited to wear watches and other metal accessories.
- All repairs should be performed using only approved spare parts, which must be installed according to their purpose and installed by an authorized contractor or authorized service representative.
- Warning: It is strictly prohibited to touch the G-MAX high voltage positive and negative poles with both hands at the same time at any time.
- Warning: Be sure to disconnect the corresponding high-voltage and low-voltage switches before performing maintenance operations on G-MAX.
- Warning: When cleaning G-MAX, it is prohibited to directly clean the high and low voltage

connectors with water.

- Warning: It is strictly prohibited to squeeze, puncture, or burn the energy storage battery to damage the system.
- Warning: If you have any questions, please contact the system supplier. Unauthorized operation is prohibited.
- Use extreme caution when this product is disconnected from the public power grid as some parts may maintain a voltage that could create a shock hazard. Before touching any part of this product, make sure the equipment and its surfaces are at contact-safe temperatures and voltages before proceeding.
- This product should be used in an environment that meets the design specifications, otherwise it may cause malfunctions. Functional abnormalities or component damage caused by failure to comply with relevant regulations are not covered by the product quality guarantee.
- Maitian Energy will not bear any legal responsibility for personal safety accidents, property losses, etc. caused by failure to comply with the contents of this manual or illegal operation of products.
- Maintenance and cleaning
- If installed outdoors, keep the sides of the G-MAX clear of leaves and other debris to maintain optimal airflow.
- G-MAX and installation site entrances and exits do not require pre-scheduled preventive maintenance. The only maintenance required by the owner is to keep G-MAX unobstructed and free of debris, especially near the air inlets and outlets.
- To clean G-MAX, use a soft, lint-free cloth, if necessary, dampen the rag with mild soap and water only.
- Do not use cleaning solvents to clean the G-MAX, or expose it to flammable and irritating chemical gases.

## 3. Product description

### 3.1 Basic features

The G-MAX liquid-cooled energy storage system optimizes and integrates high-performance three-level PCS, batteries, BMS, EMS systems, thermal management systems, power distribution and fire protection systems, and adopts a single string design to achieve zero loss tolerance in parallel connection .

The G-MAX liquid-cooled energy storage system integrates harmonic control and three-phase imbalance control, and also has the functions of peak shaving and valley filling, peak load regulation and frequency modulation. Multiple sets of cabinets can be directly connected in parallel to achieve capacity expansion and plug-and-play, forming an integrated and conveniently installed smart energy product.

### 3.2 Product Principle

Main circuit diagram:

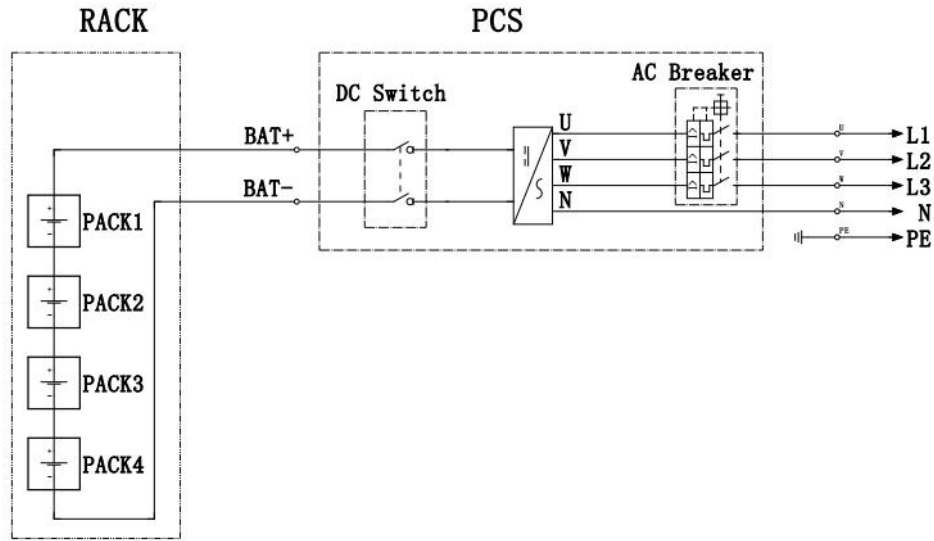

### 3.3 Operating mode

The G-MAX liquid cooling system supports both grid-connected and off-grid operation modes.

- Grid-connected operation mode

The G-MAX liquid cooling system is connected to the power grid on the AC side and internally connected to lithium batteries on the DC side. It can be applied to power expansion, photovoltaic storage and charging, peak shaving and valley filling, and other application scenarios. When connected to the grid, the energy storage converter can automatically track the grid frequency, and combine with the monitoring system to achieve smooth power output, peak shaving and valley filling, load balancing, transient active output emergency response, transient voltage emergency support, and improved power quality.

- Off-grid operation mode

The G-MAX DC side is connected to a lithium battery, and the system can output a three-phase AC voltage with a constant amplitude and frequency to achieve continuous power supply to the AC side load. When the power grid fails or is in an independent system, the device can continue to supply power to various loads.

### 3.4 EMS control mode

The control modes include manual, automatic, and proxy.

1) Manual mode: Users can manually switch sites, start and stop each energy storage subsystem under the user account, and start and stop the energy storage control system.

2) Automatic mode: Users can independently configure the control strategy for each energy storage subsystem under the account, and can add, delete, view, and edit policy templates. Policy management and policy template formulation can be carried out, and the template name, policy type, start time, end time, energy storage control type, energy storage plan power, etc. can be configured as needed.

3) Agent mode: Support third-party management systems to operate and control each energy storage subsystem of the site through this system. In proxy mode, the system will display the third-party call log to facilitate subsequent tracking and management.

### **3.5 Energy management mode**

#### **3.5.1 Constant power charge and discharge**

Through the power set by the local controller, combined with the set policy template, instructions are issued to the energy storage converter inside the energy storage integrated system to charge or discharge the battery.

#### **3.5.2 Peak shaving and valley filling**

According to the user's electricity consumption pattern, peak and valley values are set to reduce load peaks and fill load valleys, so that power generation and electricity consumption tend to be balanced. In this mode, the energy storage system maximizes its output.

- 1) When the grid power is greater than the peak value (or at the peak electricity price), the energy storage integrated system starts to discharge.
- 2) When the grid power is less than the valley value (or is in the valley electricity price), the energy storage integrated system starts charging.

#### **3.5.3 Demand control**

When the photovoltaic system (if any) maximizes its output, if the load power still exceeds the set demand power, the local controller controls the output of the energy storage system to stabilize the power that exceeds the demand and increase the economy of the system.

#### **3.5.4 Anti-backflow control**

Prevent energy storage discharge from feeding into the grid.

### 3.6 Product size

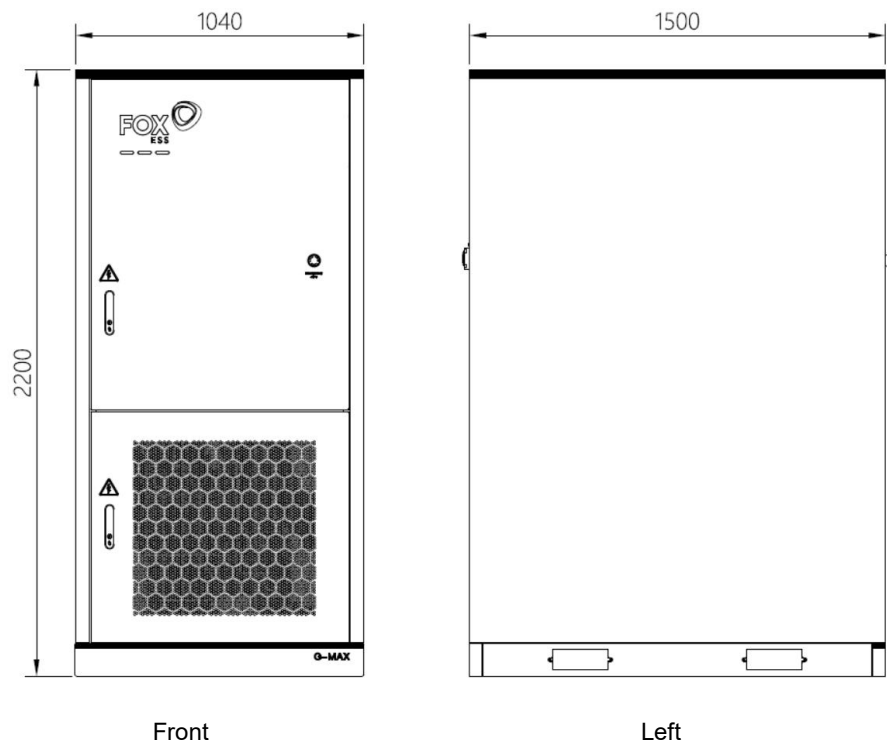

Front

Left

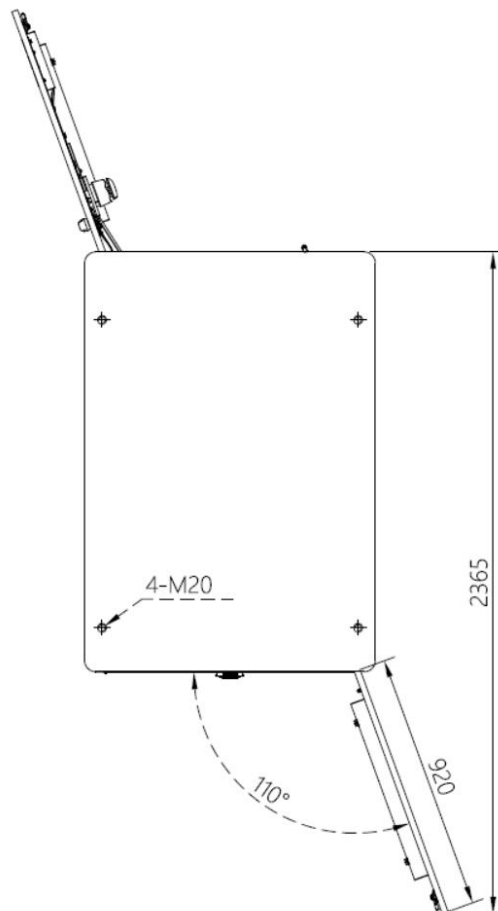

Lifting holes, door opening radius and maximum door opening angle

### 3.7 System technical parameters

Items	Specification
<b>DC parameter</b>	
Cell technology	LiFePO4 3.2V/280Ah
Battery pack configuration	53.76kWh
System battery string configuration	1P240S
Battery System Capacity	215kWh
Battery rated voltage	768Vdc
Rated Charge/Discharge Rate	≤0.5C
Depth of discharge	0-95%
DC protection	FUSE
Battery pack degree of protection	IP65
Cooling type	Liquid cooling
<b>PCS parameter</b>	
Rated AC input/output Power	100kW
Max. continuous AC input/output Power	110kW
THDi	<3%
Nominal Voltage	230/400 V a.c.,3W/N/PE
Power Factor	>0.99
Adjustable Power Factor Range	-1~1 (leading-lagging)
Nominal Frequency	50/60 Hz
<b>AC parameter</b>	
Round Trip Efficiency	>90%
Communication Interfaces	RS485/Ethernet
Ingress Protection	IP54
Cooling type	Intelligent air cooling
Altitude	≤3000m
Operation Temperature	-25~55 °C
Relative humidity	0 - 95% (non-condensing)
Noise	<75db@1m
Dimension(W*D*H)	1040mm × 1500mm × 2200mm
Fire safety equipment	Aerosol Fire Extinguisher Device
Certificate	IEC 62619/IEC 60730-1 appended H/IEC 61000-6-2, 4/UN 38.3

### 3.8 Component Description

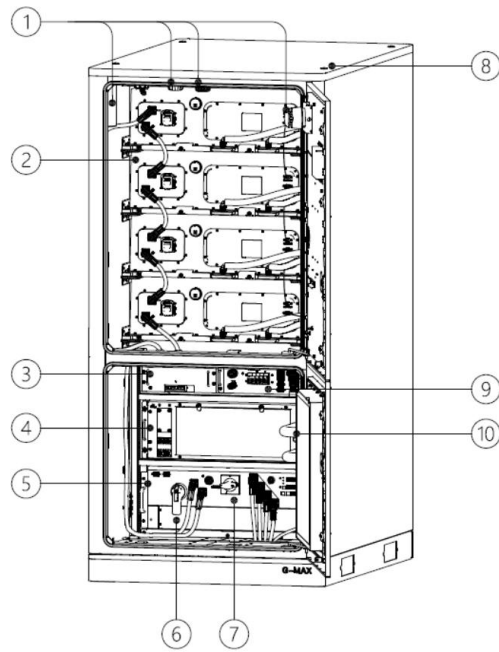

Front

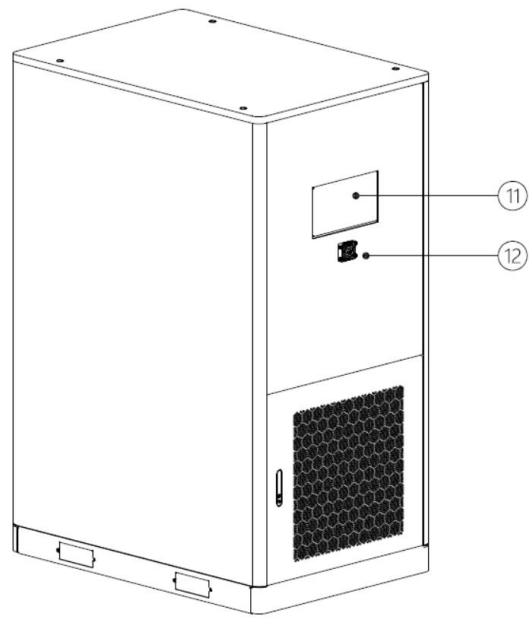

Later

Serial number	Name
①	Fire safety equipment
②	Battery pack configuration
③	EMS
④	Temperature controller
⑤	PCS
⑥	AC Breaker
⑦	DC Switch
⑧	Hole for hoist
⑨	Integrated distribution box
⑩	Liquid cooling pipe
⑪	Pressure Release Device
⑫	Explosion-proof valve

### 3.9 Panel Introduction

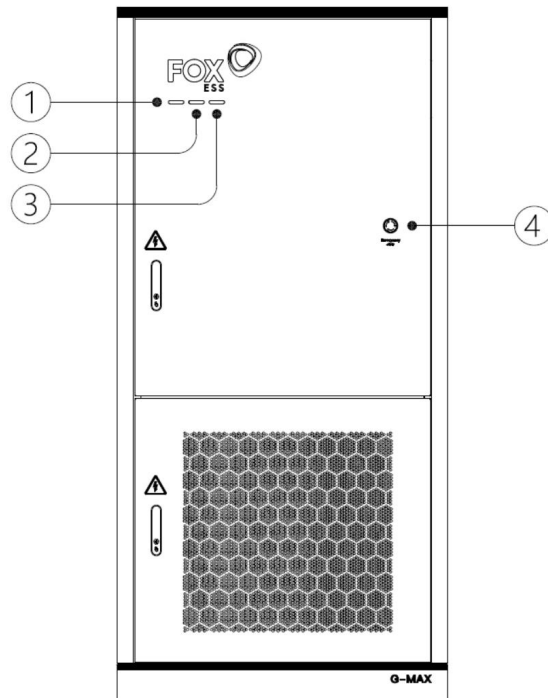

Serial No.	Function
1	"POWER" indicator: the cabinet switch is closed, the system is energized, the indicator light is blue.
2	RUN indicator: When the system is charging or discharging, the indicator is blue.
3	"RUN&FAULT" indicator: When the system is running normally (charging or discharging), the blue light is on. When the system fails, the red light is on.
4	Emergency stop button: When the equipment is in abnormal state, press the button to stop the system operation.

The above pictures are for reference only and are subject to the real thing.

## 4. Unpacking and handling

### 4.1 Check after unpacking

After unpacking, the following items must be checked:

Serial number	Check item	Completion
1	The appearance shall be free of damage, scratches, dents, etc.	
2	The product comes with a complete range of options and accessories.	
3	The nameplate information is consistent with the ordered product model	
4	The warning label is not damaged, scratched, blurred, etc.	

## **4.2 Unpacking precautions**

- It is not allowed to remove the packaging of G-MAX during storage, and it can only be removed when it is installed.
- When receiving goods from the transport company, be sure to carefully inspect the products and check each item received against the delivery note. If any goods are missing or damaged, notify the transport company immediately upon discovery.
- Before unpacking, please check whether the outer packaging of the product is intact and whether it is damaged, soaked, damp, deformed, etc.
- Please open the package in order of layers and do not knock violently.
- When unpacking, please check whether the product and its accessories have any damage, rust, or bruises on the surface.

## **4.3 storage**

- When storing, please pack the products in our company's packaging boxes according to the original packaging.
- The temperature should be kept between  $-30^{\circ}\text{C}$  and  $+60^{\circ}\text{C}$ .
- The device must be placed in a clean and dry space, and avoid being placed in places exposed to water splashing, rain, humidity, high temperature or outdoor exposure.
- There are no harmful gases, flammable, explosive products or corrosive chemicals in the storage space.
- When storing for a long time, the equipment must be covered or appropriate measures must be taken to ensure that it is not contaminated or affected by the environment.
- Avoid mechanical impact, heavy pressure, strong electric fields and strong magnetic fields.
- Avoid direct sunlight and keep the distance  $\geq 2\text{m}$  from heat sources.

### **Under the above stipulated conditions:**

- Recharged to 50% SOC at least once within 6 months after leaving the factory;
- Under the above-mentioned conditions, products stored for more than 12 months must undergo capacity verification tests and re-inspections, and can only be used after passing the test.

## **4.4 transportation**

- Please package the product strictly before transporting it by vehicle. Closed boxes must be used for long-distance transportation.
- It is strictly prohibited to transport this product together with equipment or items that may affect or damage the product.

### **4.4.1 Forklift transportation**

- It is necessary to test the fork. If it is not suitable, the forklift foot position needs to be adjusted. After testing that the fork is suitable, lift the G-MAX and move it to the appropriate position.
- During transportation, the G-MAX tilt angle must be less than  $10^{\circ}$ , and the undulation height must be as low as possible.
- It is forbidden to transport hydraulic trucks over long distances or on slopes, otherwise the hydraulic trucks may be damaged.
- Please handle it gently when taking off and landing to avoid shock or vibration. When lowering the forklift, be careful not to press your feet.
- Considering that the equipment is high and may block the driver's sight, it is recommended to arrange for personnel to guide the driver depending on the situation.

#### 4.4.2 Crane handling

- Carry out a test lifting to confirm that the straps can bear the weight of G-MAX and there is no tilt when lifting.
- After lifting, the swing angle must be less than 10°.
- Before moving, make sure that the cabinet door is locked to avoid injuries caused by sudden opening during transportation.
- Lift and place gently when taking off and landing to avoid shock or vibration.

#### 4.5 Transportation before unpacking

##### 4.5.1 Transportation method

There are two ways to transport unopened packaging: forklift transportation and crane transportation.

##### 4.5.2 Forklift handling steps

Packaged G-MAX full container products are moved by forklift on the pallet under the packaging, and the operators must be trained.

Adjust the width of the forklift foot so that the center of gravity falls in the middle of the forklift foot. Insert it in the position shown in the figure below.

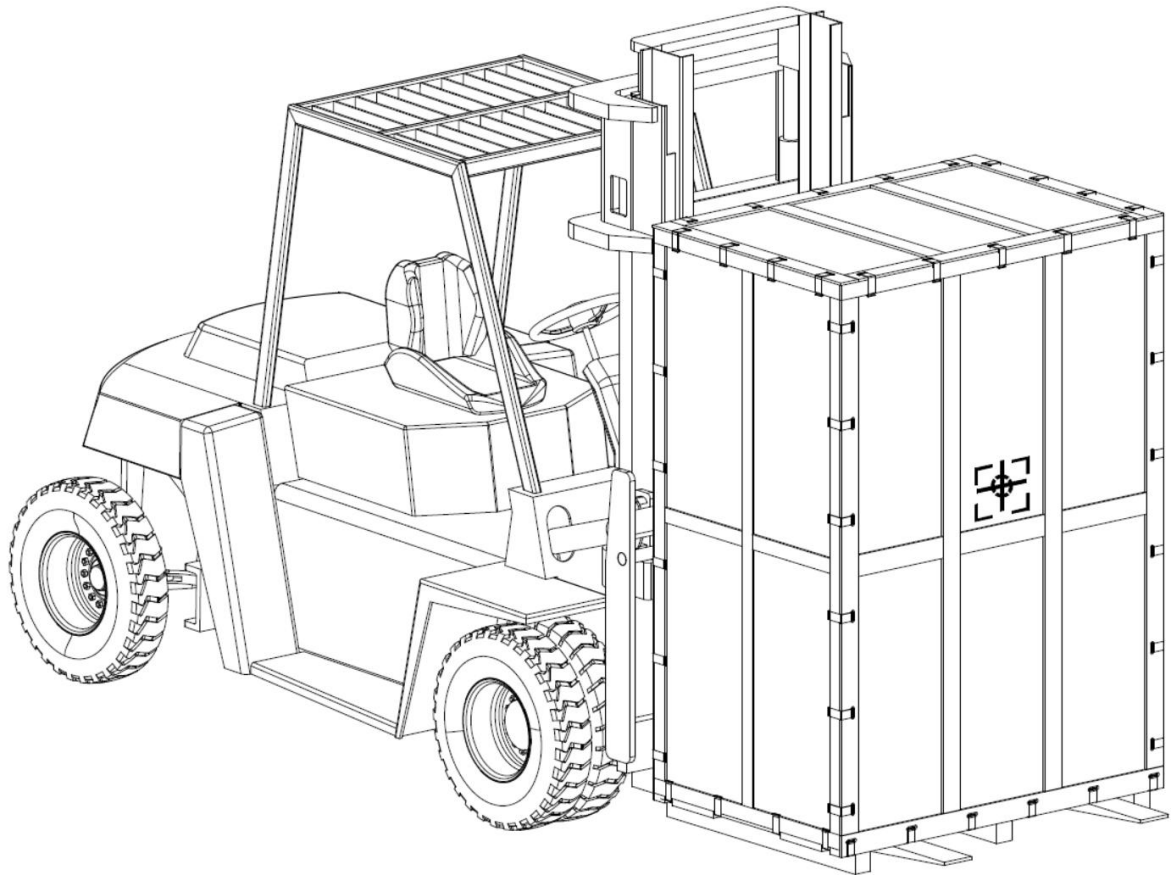

Forklift handling diagram

##### 4.5.3 Crane handling step

Use flexible slings or straps. A single strap must be able to withstand a weight of no less than 3 tons. Use the straps to tighten the cabinet and follow the steps below.

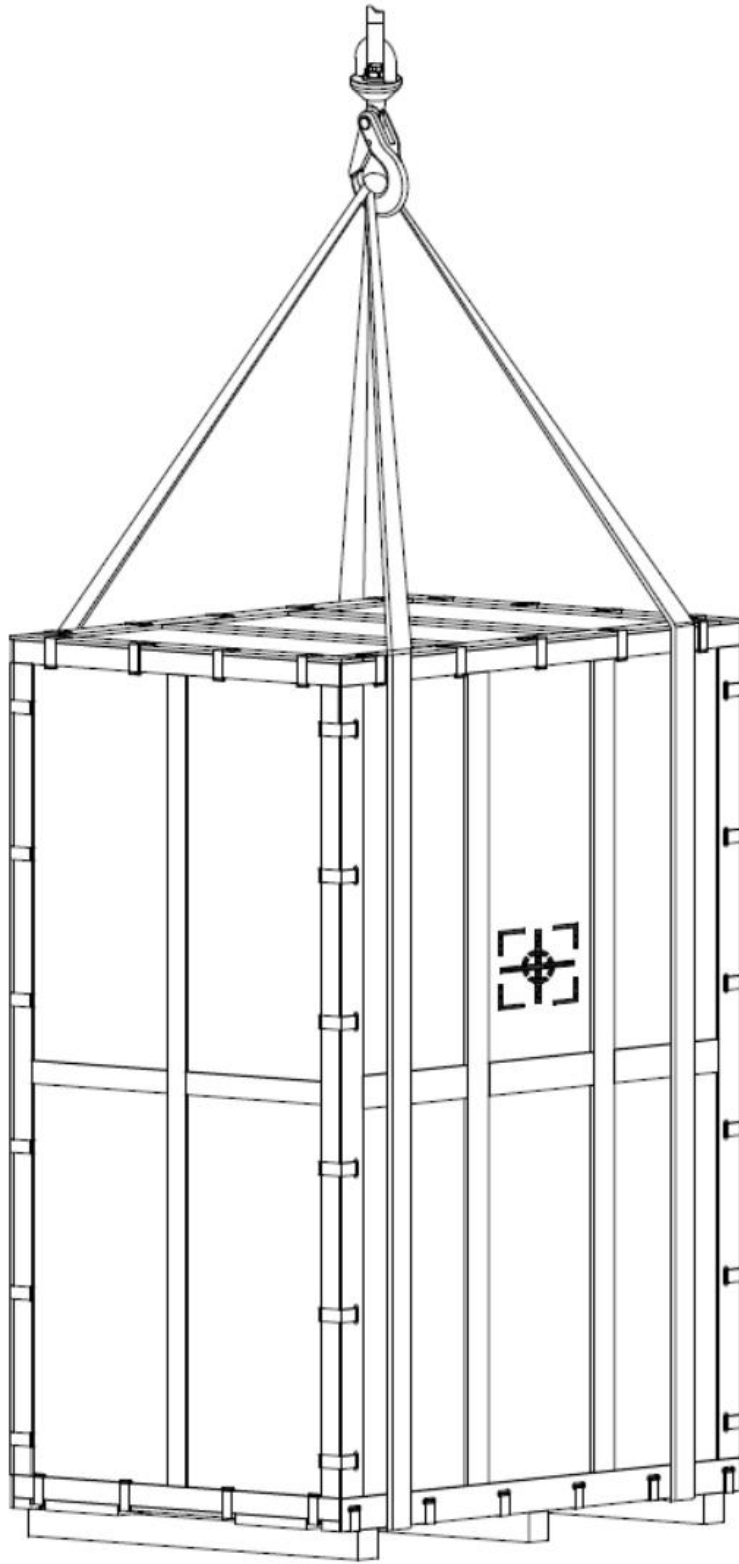

Schematic diagram of lifting and handling with packaging

**Notice**

The hook should be at least 1m away from the top of the cabinet.

The tilt of the cabinet should be less than 10°.

## 4.6 Transportation after unpacking

### 4.6.1 Forklift transportation

Adjust the width of the forklift feet so that the center of gravity falls on the center of the forklift feet.

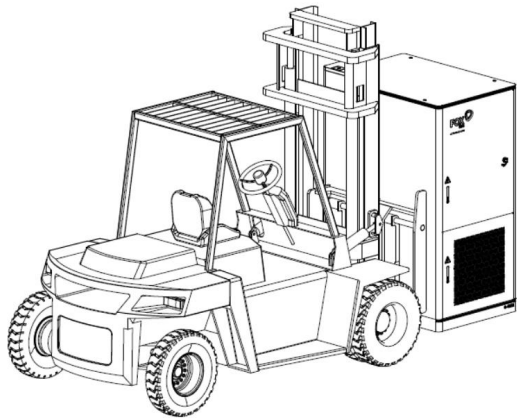

side transport

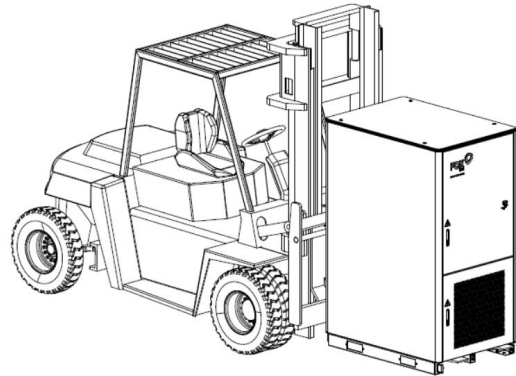

front cross transport

Schematic diagram of forklift transportation without packaging

### 4.6.2 Crane handling

When moving without packaging, use flexible slings or straps. A single strap can bear a weight of no less than 3 tons.

Tie the cabinet tightly with straps and follow the diagram below.

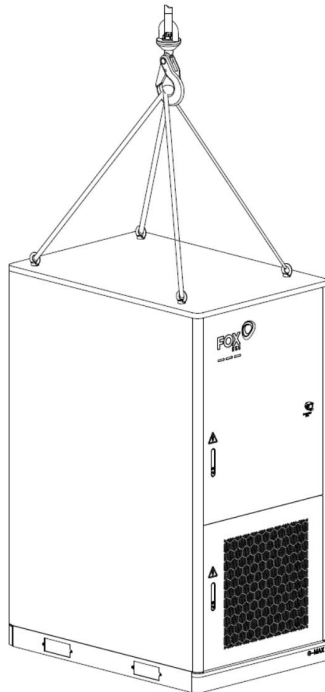

Schematic diagram of hoisting and transportation without packaging

#### Notice

The hook should be at least 1m away from the top of the cabinet.

The tilt of the cabinet should be less than 10°.

## 5. Engineering Installation

### 5.1 Installation Tips

During installation, ignoring the following safety tips may result in equipment damage, personal injury or serious casualties. Please strictly follow the following safety tips.

- Installation must be performed by professionals who follow all warnings and correctly install the equipment.
- Before installation, make sure that the mechanical strength of the installation location is sufficient to support the weight of the equipment, otherwise it may cause mechanical hazards.
- During installation, do not wear loose clothing or jewelry, otherwise there may be a risk of electric shock!
- To facilitate installation and maintenance, it is recommended to leave enough space around the equipment: sufficient cooling airflow, required clearance, space required for cables and cable support structure.
- Make sure that any spanning elements or racks with components installed are properly grounded and that the connection surfaces are unpainted.
- Nickel-plated copper is recommended, but aluminum can also be used.
- Before connecting aluminum busbars, remove the oxide layer and apply a suitable anti-oxidation caulking compound.

### 5.2 Preparation before installation

#### 5.2.1 Installation environment requirements

Project	Environmental requirements
Installation site requirements	<ul style="list-style-type: none"> <li>• Good ventilation must be maintained.</li> <li>• The air inlet and outlet must be professionally protected from rain, wind, sand and dust.</li> <li>• Make sure there are no trees around the installation location to prevent strong winds from blowing down branches or leaves that may block the product door or air inlet.</li> <li>• Necessary fireproofing, waterproofing and rodent-proofing treatments are required.</li> <li>• Keep away from areas where toxic and harmful gases are concentrated.</li> <li>• Keep away from flammable, explosive and corrosive items.</li> </ul>
Foundation requirements	<ul style="list-style-type: none"> <li>• The installation surface must be flat and dry, and no water accumulation is allowed on the ground.</li> <li>• Make sure the ground is level and can bear the weight of the G-MAX.</li> </ul>
Space requirements	Sufficient space must be left in front, behind, left, right, and above the G-MAX for heat dissipation, maintenance, and escape.
Altitude	3000m, >2000m needs to be reduced in capacity.
Temperature	-25 °C ~+55 °C, operate with derating above +40°C.
Relative humidity	0%~95%.

The intrusion of moisture can easily damage G-MAX! To ensure the normal use of G-MAX:

- Do not open the cabinet door when the air humidity exceeds 95%.
- Avoid opening the cabinet door or performing maintenance or repair operations in rainy, thunderstorm or humid weather conditions.

### 5.2.2 Installation site requirements

#### (1) Installation space requirements

Sufficient maintenance space and heat dissipation and ventilation space must be reserved at the G-MAX installation location. The recommended space dimensions are as shown in the figure below.

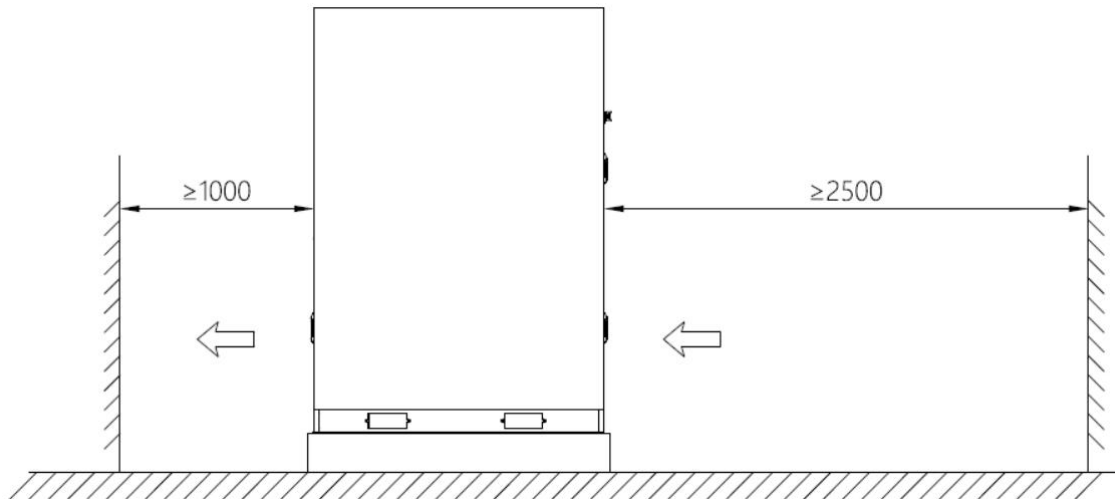

#### (2) Foundation requirements

G-MAX must be installed on concrete or other non-combustible surfaces. The installation surface must be level, firm, flat, and have sufficient bearing capacity. No dents or tilts are allowed.

When building the foundation, you need to consider the G-MAX cable outlet and reserve trenches or cable entry holes. Please refer to the figure below for the installation hole location diagram.

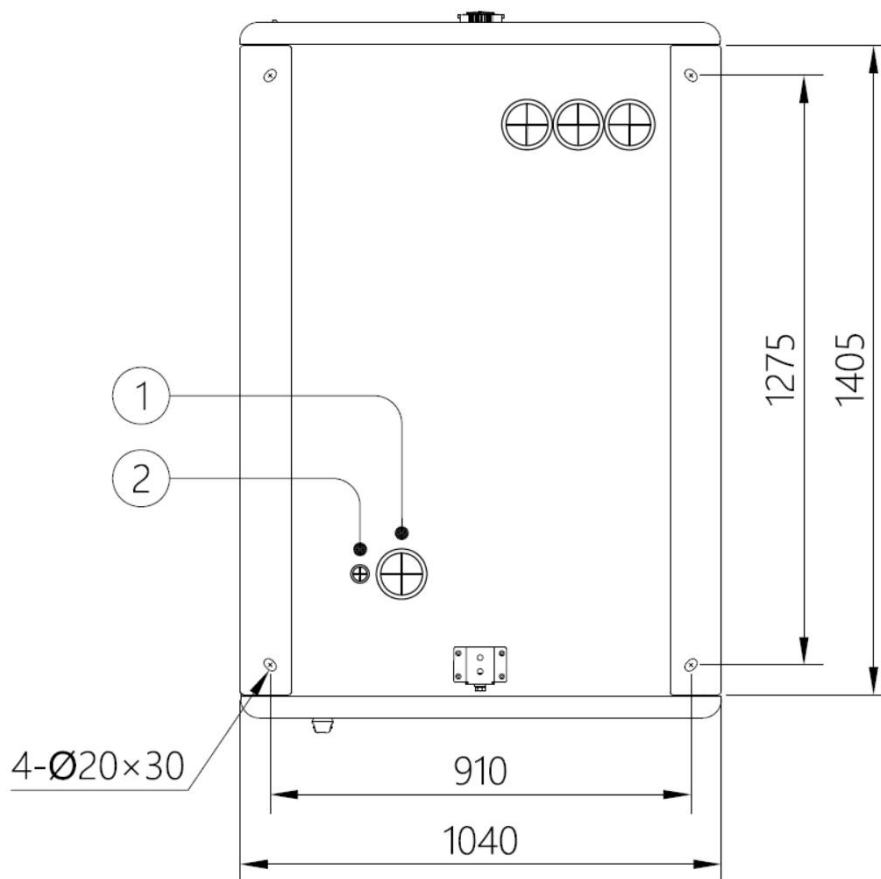

Installation hole diagram (unit: mm)

Project	Illustrate
①	Communication inlet and outlet holes
②	AC cable outlet

**Note**

- The following foundation drawings cannot be used as final construction drawings and are for reference only.
- During construction, ensure that the bottom of the equipment is higher than the local historical highest water level.
- Equipment (including height, embedded parts, wiring pipes , etc.) is adjusted based on process and on-site.
- The height of the top mark of the equipment foundation can be adjusted according to the actual needs of the equipment and site.
- The equipment foundation shall be configured according to the total weight of the equipment of 3 tons. When the weight of the equipment exceeds the design, it needs to be reviewed.
- If installed on hard ground, it is recommended to use bolt connection. The connection points should be adjusted according to the actual conditions on site.

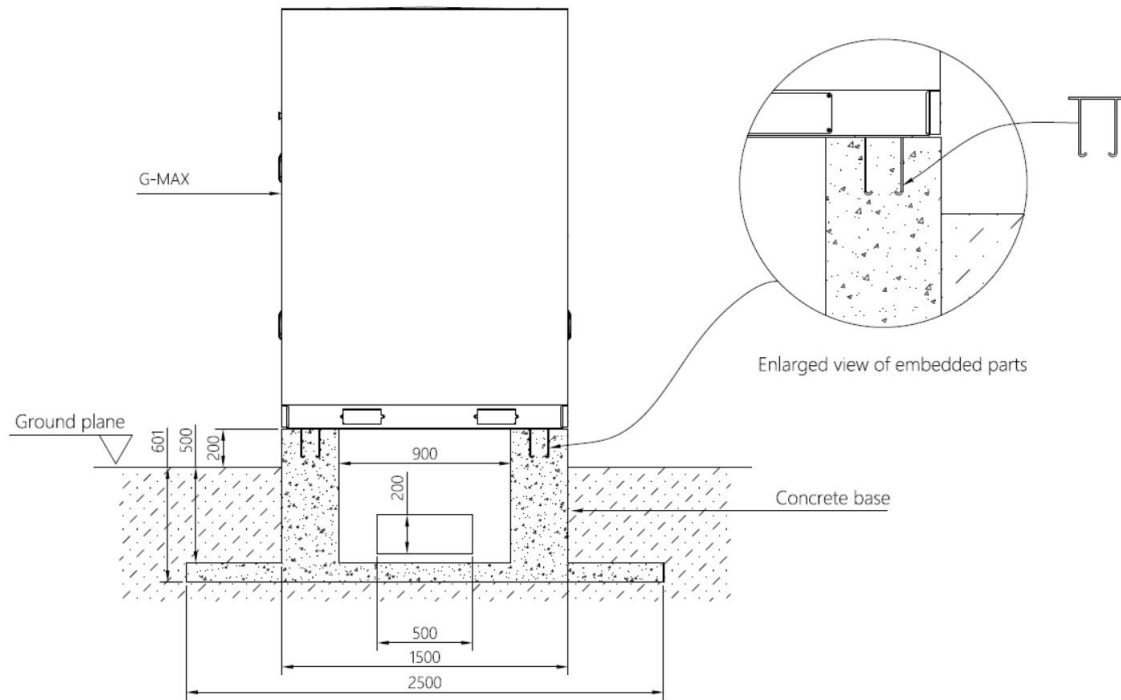

Sectional view of mounting base (side)

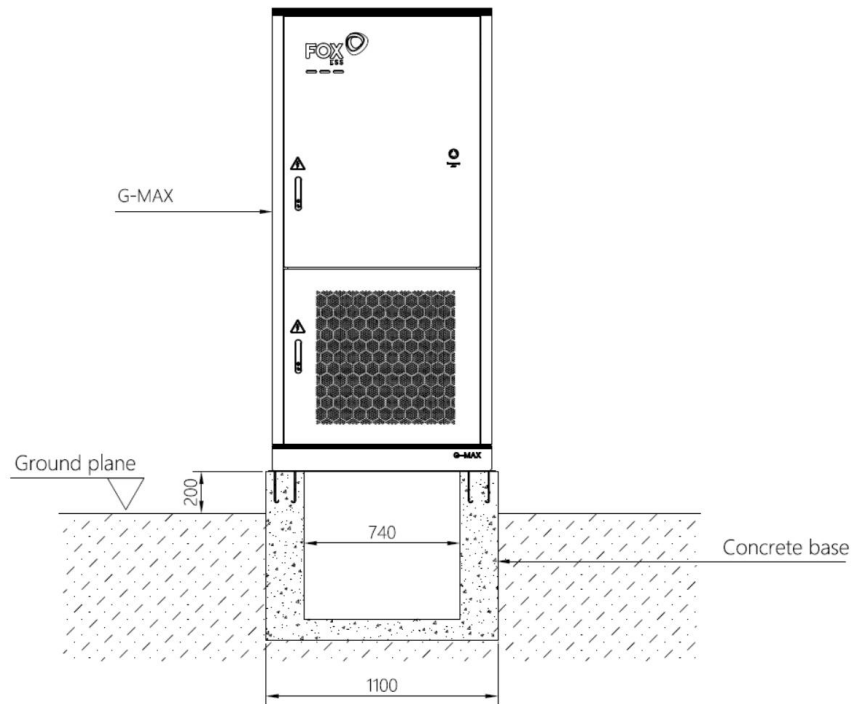

Sectional view of installation base (front)

### (3) Gutter requirements

G-MAX adopts the bottom cable entry method. To prevent foreign objects from entering, there is no cable entry hole on the side of the G-MAX cabinet. The cables must be entered through the trench. Therefore, a trench must be preset on site. The trench has the following requirements:

- Since G-MAX uses bottom cable entry, the trench must have necessary dust and rodent-proof design to prevent foreign objects from entering.

- The trench needs to have necessary waterproof and moisture-proof design to prevent the cables from aging and short-circuiting, which will affect the normal operation of G-MAX.
- Since G-MAX has a large power, the required cables are thicker, so the cross-sectional area of the cables must be fully considered when designing the trench.

### 5.3 Ground connection

#### Note meaning

The grounding method must comply with the standards and regulations of the installation location.

The grounding connection is divided into system grounding and shell grounding.

#### ① System grounding

To ground the system, the user lays the PE wire into the cabinet through the incoming cable. The wire diameter is required to be  $\geq 35\text{mm}^2$ . The grounding position is as follows:

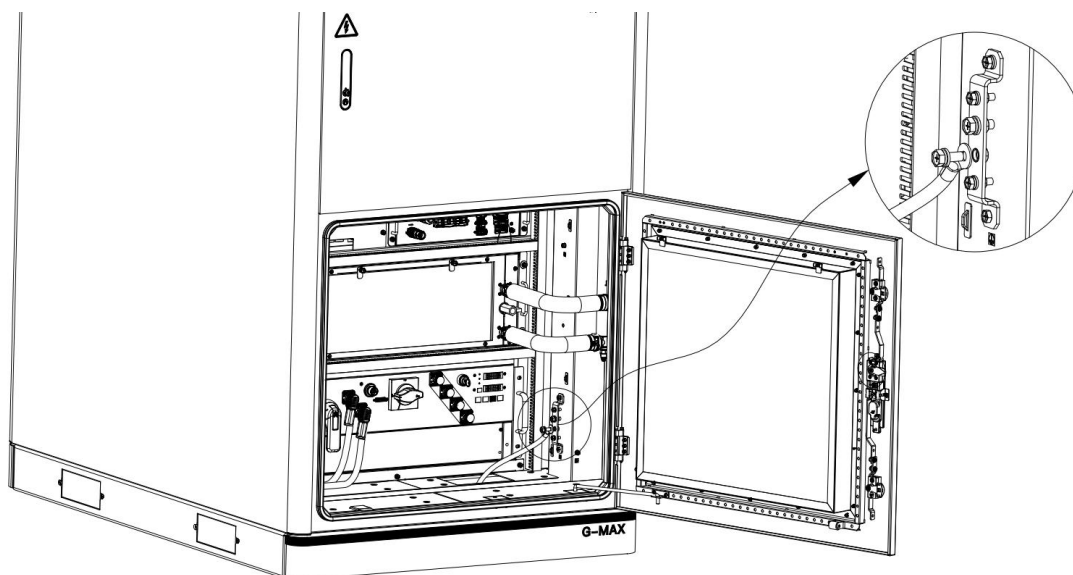

#### ② Shell grounding

There are two methods for grounding the shell: welding and fixing with grounding flat steel or fixing with grounding cables. The location of the grounding point is as shown below:

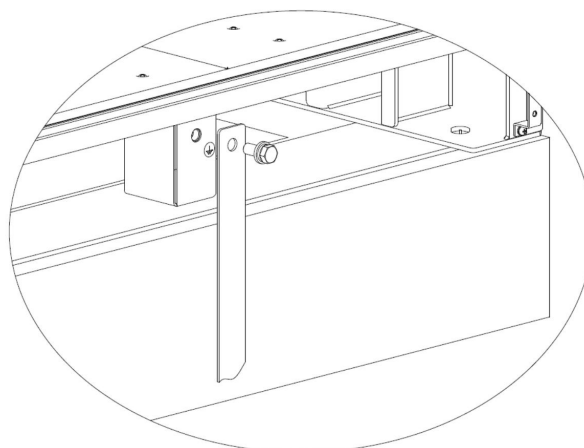

## 6. Electrical installation

### 6.1 Wiring preparation

#### 6.1.1 Cable requirements

The requirements for cables used within G-MAX 's nearest installation distance of 100 meters are as follows:

Name	Type	Recommended wire diameter (mm <sup>2</sup> )
External ground wire	Outdoor ground wires of 1000V and above	35mm <sup>2</sup> (yellow green)
AC side input line	Outdoor multi-core or single-core cables of 400V and above	U/V/W three-phase is 70mm <sup>2</sup> , OD: 16.5±1.0mm N line is 35mm <sup>2</sup> (blue), OD: 11.6±0.5mm

#### 6.1.2 Crimp end AC terminal

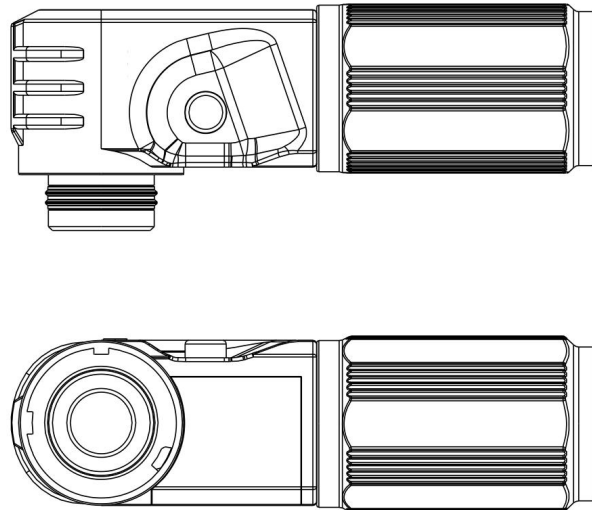

**Terminal diagram**

1. Unscrew the nut and clamp coil.

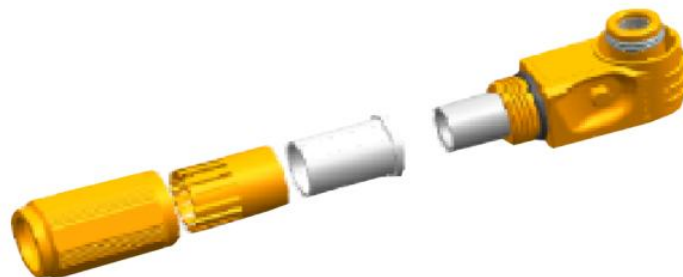

2. Peel off the outer sheath of the cable.



3. Put the nut and clamp coil onto the cable.

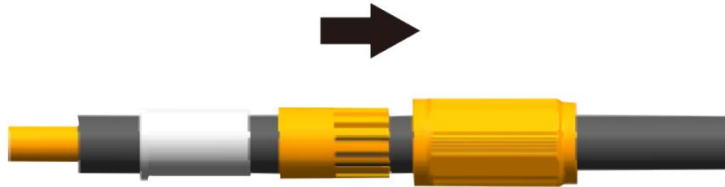

4. Insert the conductor portion into the wire lug.

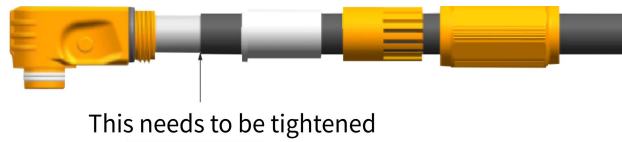

5. Crimp the conductor portion of the cable into the lug as shown below.

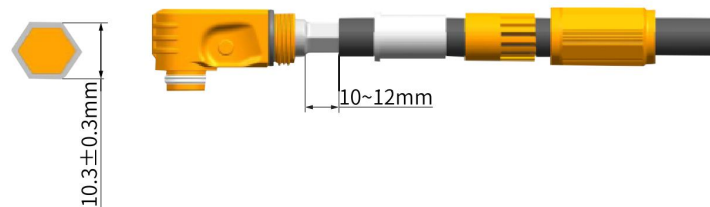

6. Push the clamp coil and nut to the plug and lock.

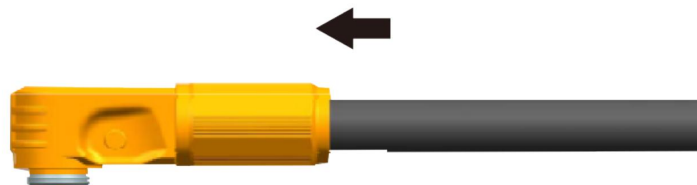

### **6.1.3 AC input wiring**

#### **(1) Cable requirements**

To prevent unexpected interruption of the connection between the converter and the grid caused by excessive AC cable impedance, be sure to select a reasonable AC side cable diameter according to Table 6-1;

The cable is grounded, it is necessary to add identification (in any form) to the cable to avoid abnormal wiring;

#### **(2) Wiring steps**

Before connecting to the grid, first ensure that the grid voltage and frequency meet the requirements of the converter. For detailed parameters, see the technical parameter table.

Before making electrical connections, make sure all cables are de-energized.

The G-MAX electrical connection is completed, it is forbidden to close the AC circuit breaker switch, and the AC circuit breaker is in the OFF state, as shown in the figure.

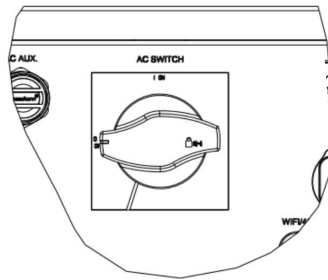

**Step 1:** Ensure that the external AC circuit breaker is disconnected and will not accidentally close.

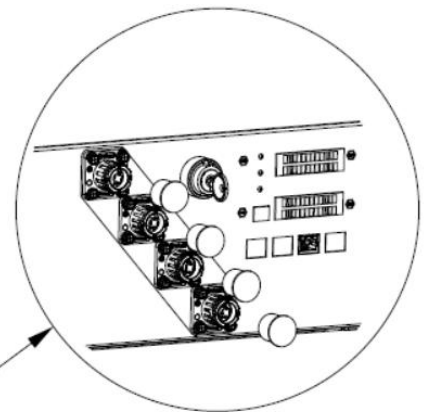
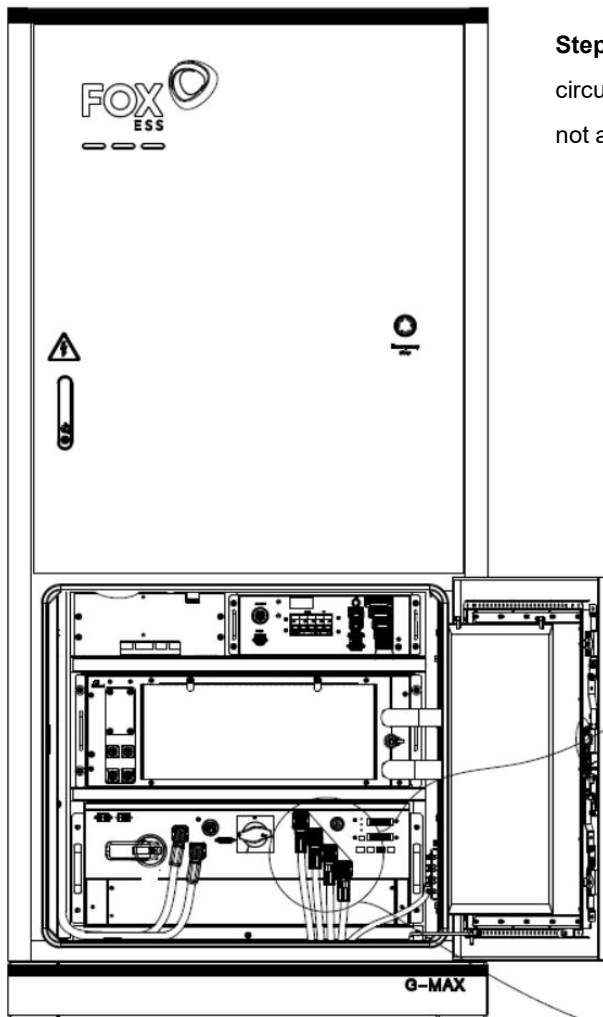

**Step 2:** Remove the dust caps from the AC U, V, W, and N receptacles.

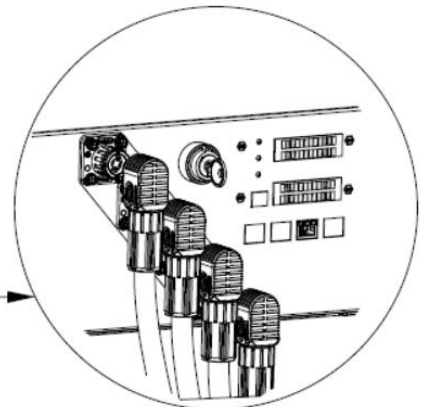

**Step 3:** Strip the U, V, W and N cables to appropriate lengths with wire strippers, put them into the plug shell and the sealing sleeve; crimp them onto the plug terminals with hydraulic crimpers, assemble the rubber sleeve and the plug shell, and finally insert the plugs into the corresponding sockets of the converter.

## **6.2 G-MAX power on**

### **6.2.1 Check before powering on**

Before powering on, please check the following items carefully to ensure they are correct.

- Check whether the positive and negative terminal connections of the battery PACK and the PCS power cable connections are correct.
- Check that the battery PACK, PCS, battery wiring cabinet power loop wiring and all connector plugs and sockets are not loose.
- Check that there should be no short circuit between the positive and negative poles of PACK.
- Check that the battery PACK, PCS, power distribution box, battery power supply cabinet auxiliary power supply wiring and communication wiring should be reliably connected.
- Check that the battery PACK, PCS, power distribution box, liquid cooling unit, and EMS should be reliably grounded.
- Check the battery PACK and liquid cooling pipes for leaks of coolant.
- The internal circuit breaker of the distribution box in the electrical compartment, the PCS AC side circuit breaker, and the PCS DC side disconnecter should be in the open state .
- The protective cover inside the device is securely installed.
- Use a multimeter to check whether the AC and DC voltages meet the starting conditions and there is no overvoltage hazard.
- All safety signs and warning labels on the cabinet are firmly affixed and clearly visible.
- Check to make sure no tools or parts have been left inside the equipment.

### **6.2.2 Power-on steps**

Step 1 Use a multimeter to test the voltage between BAT+ and BAT-. The voltage range is 672-876 Vdc.

Step 2 Close the PCS DC Switch. After about 3 seconds, the Power indicator on the PCS panel starts flashing and gradually returns to slow flashing .

Step 3 Close the PCS AC molded case circuit breaker.

Step 4 Close the Liquid and Tr circuit breakers on the power distribution box.

Step 5 Check whether the cabinet door indicator light is normal.

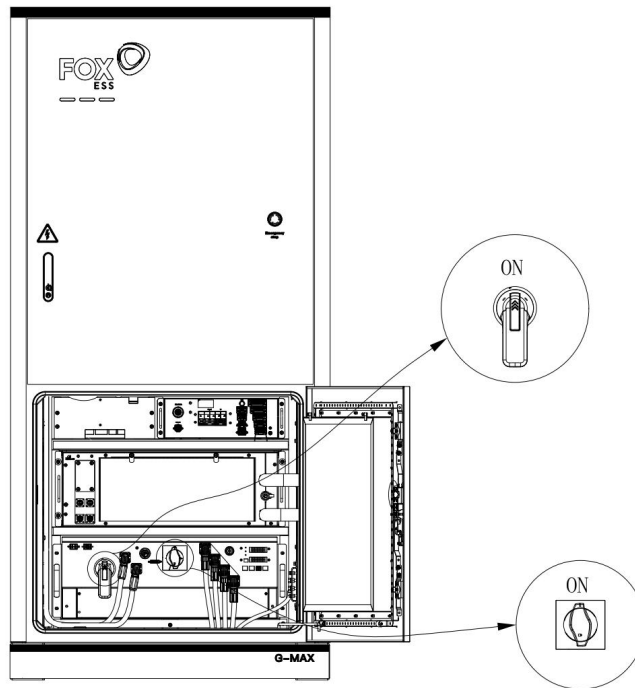

\*The above pictures are for reference only, please refer to the actual product received!

### 6.3 G-MAX Shutdown

Shutdown is usually divided into two situations: shutdown for normal maintenance or overhaul and shutdown for failure or crisis. According to the two different situations , perform the shutdown steps described in this section .

#### 6.3.1 Normal shutdown

Normal maintenance or inspection, follow the following procedures:

PCS shutdown through the shutdown operation command on the WEB interface

Step 2 Open the electrical cabinet door

Step 3 Make sure that the PCS AC side circuit breaker and DC load switch are both closed .

Step 4 Disconnect the Liquid circuit breaker and Tr circuit breaker of the power distribution box

Step 5 Disconnect the PCS AC side circuit breaker AC Breaker

Step 6 Disconnect the PCS DC side isolation switch DC Switch

-- Finish

#### warn:

When the machine is working normally, it is strictly forbidden to disconnect the DC load switch directly to avoid the danger of arcing and damage to the DC load switch. In severe cases, it may also cause damage to the PCS .

#### 6.3.2 Shutdown in case of malfunction or emergency

In case of emergency or failure, follow the following procedures:

Step 1 Press the emergency stop button

Step 2 Open the electrical cabinet door

Step 3 Make sure both the AC circuit breaker and DC load switch are closed

Step 4 Disconnect the PCS AC side circuit breaker AC Breaker

Step 5 Disconnect the PCS DC side isolation switch DC Switch

Step 6 Disconnect the Liquid circuit breaker and Tr circuit breaker of the power distribution box

-- Finish

**warn :**

- The emergency stop button is only used when the machine fails or is in critical condition. During normal shutdown, the shutdown operation should be performed through the button shutdown command on the WEB interface.
- If the situation is urgent, be sure to press the emergency stop button directly to ensure quick response.

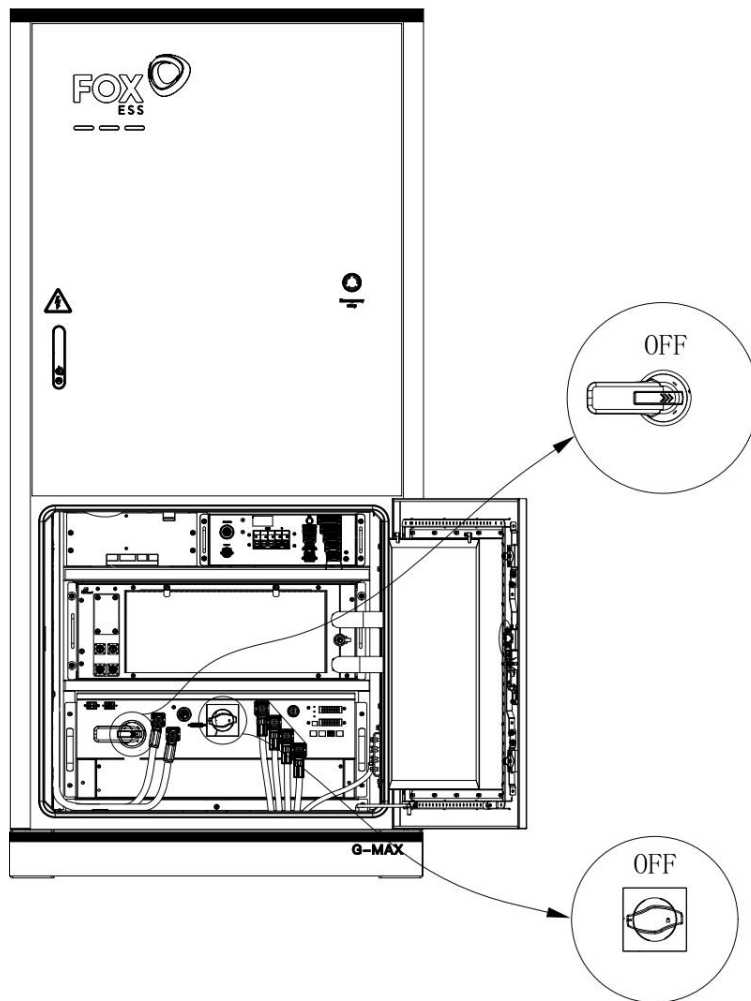

\*The above pictures are for reference only, please refer to the actual item received!

## 7. Daily care and maintenance

Due to the influence of environmental temperature, humidity, dust and vibration, the components inside the energy storage cabinet will age, which may cause potential failure of the energy storage cabinet or reduce the service life of the cabinet. Therefore, it is necessary to perform daily and regular maintenance on the energy storage cabinet .

- Only personnel with professional qualifications and authorization can perform maintenance and other operations on the energy storage integration system.
- After shutting down, please wait at least 5 minutes before opening the cabinet door. Before performing maintenance work, make sure that the inside of the equipment is completely de-energized.
- After the power is disconnected, a warning sign must be hung at the disconnection point to prevent someone from powering on during maintenance.
- To avoid unexpected dangers, maintenance personnel should wear insulating protective equipment during maintenance.
- When performing maintenance work, do not leave metal parts such as screws and washers in the energy storage integrated system, otherwise the equipment may be damaged!

### **Notice**

1) The entry of wind, sand and moisture may damage the electrical equipment in the energy storage integrated system or affect the operating performance of the equipment!

2) In windy and sandy seasons, or when the relative humidity in the surrounding environment is greater than 95%, do not open the equipment cabinet door in the energy storage integrated system.

All maintenance work can only be started when there is no wind or sand and the weather is clear and dry.

If only the AC and DC switches are disconnected, the cable connection terminals inside the AC and DC cabinets of the energy storage integrated system are still energized! To avoid the risk of electric shock, before maintenance and repair operations:

1) Disconnect all AC and DC side switches.

2) Disconnect the front and rear circuit breakers of the energy storage integrated system.

## 7.1 Daily inspection items

Daily inspection items are implemented according to the following points:

Table 7-1 List of daily inspection items

Serial number	Daily inspection items	Confirm
1	The energy storage cabinet need to be monitored in real time, and designated personnel should be assigned to observe at designated locations. If abnormal operation or abnormal voltage and current are found, maintenance should be carried out in a timely manner.	<input type="checkbox"/>
2	Check whether there is any abnormal sound inside the energy storage cabinet.	<input type="checkbox"/>
3	Check whether there is any peculiar smell inside the energy storage cabinet.	<input type="checkbox"/>
4	Through the EMS client and observe that the temperature is within the normal range.	<input type="checkbox"/>
5	Check that the outer surface of the chassis is not damaged, use water or alcohol to clean the dirty areas on the surface, and touch up the damaged paint on the surface. Please refer to the detailed steps.	<input type="checkbox"/>

## 7.2 Regular inspection items

Regular inspections mainly focus on daily inspections and areas that are difficult to inspect during daily operation:

Table 7-2 List of regular inspection items

Serial number	Regular inspection items	Confirm
1	Check that there is no damage or rust on the appearance of the equipment.	<input type="checkbox"/>
2	The internal temperature of the equipment was checked with an infrared temperature measuring instrument and no abnormality was found.	<input type="checkbox"/>
3	Check whether the equipment's ventilation, ambient temperature, humidity, dust and other environmental conditions meet the requirements.	<input type="checkbox"/>
4	Check whether the insulation layer of the cable is aging or damaged. If necessary, add corresponding insulation measures or replace the cable.	<input type="checkbox"/>
5	Check that there are no signs of aging or burning on the connecting bolts, and use tools to confirm that they are in a tightened state.	<input type="checkbox"/>

## 7.3 Liquid Cooler Maintenance Work

In order to ensure the normal operation of the liquid cooler, regular maintenance is required.

Warning: All maintenance work must be performed by qualified professional technicians. Before performing any maintenance, please disconnect the power supply and signal line of the liquid cooler should be connected after the maintenance work is completed.

Table 7-3 Liquid Cooler Maintenance :

Maintenance Items	Maintaining standards	Maintenance cycle	Detection method	Approach
Appearance of the unit	The unit is clean and free of dust and dirt	6 months	Visual inspection	After power off for 1 minute, use a brush or cotton cloth to remove dust and dirt from the unit.
Fan operation reliability	There is no dust or other foreign matter blocking the air outlet. The fan blades are not damaged, and the fan rotates smoothly without abnormal noise.	6 months	Visual inspection	After power is turned off for 1 minute, use a brush to clean the dust on the fan, tighten the fan, and check whether there are any internal cables interfering with the fan's rotation. Clean any foreign objects at the air outlet.
Reliability of power cables and power terminals in wiring panels	The power plug is not loose	6 months	Visual inspection	After the power is turned off for 1 minute, disconnect the loose power plug quick connector and reconnect it.
	The power cable is not aged, damaged, abnormally heated, or has other abnormalities.	6 months	Visual inspection	Contact the manufacturer for replacement.
	No dust in the wiring panel	6 months	Visual inspection	After turning off the power for 1 minute, use a brush to clean the dust.
Condenser cleaning	The condenser is free of dust and foreign matter	6 months	Visual inspection	After power off for 1 minute, use high pressure gas to blow out the condenser.
	The fins have no serious bending deformation	6 months	Visual inspection	After power off for 1 minute, use a fin comb or other tool to make corrections.
Cooling medium	Concentration meets the range requirements PH and electrolytes Concentration meets the requirements No dirt, sediment, algae, etc.	6 months	Coolant tester	Contact the manufacturer to replace the cooling liquid.
Pipeline appearance	No damage, deformation or corrosion on the exterior	6 months	Visual inspection	After power off for 1 minute, drain the coolant and replace the corresponding pipeline.
Pipeline reliability	The pipes are fixed and the connection joints are not loose.	6 months	Visual inspection	After power off for 1 minute, tighten the loose parts.
Valve body reliability	No failure or damage to the valve body	6 months	Commissioning	After power off for 1 minute, drain the coolant and replace the corresponding valve parts.

## 7.4 Other maintenance projects

To ensure the normal operation of the energy storage cabinet, please refer to Table 7-4 to perform regular maintenance on the energy storage cabinet.

Table 7-4 Other project maintenance:

Maintenance Project	Maintenance methods	Maintenance cycle
Internal electrical component inspection	Check the following items and perform maintenance a. Check the dust on the circuit board and components. If there is too much dust, use tools to clean it.	half a year
Security function check	Check the following items and perform maintenance a. Check the safety warning signs of the energy storage system. If any damage or blur is found, please replace it in time. b. Check whether the emergency stop function of the equipment is normal	half a year
Inside the device	Check the following items and perform maintenance a. Check whether there is pollution, foreign matter, dust inside the equipment and clean it	one year
Energy storage cabinet wiring harness inspection	Check the following items and perform maintenance a. Check whether the equipment wiring harness rubber sleeve is damaged, whether the copper wire is exposed, damaged, rusted, etc., and whether the connecting screws are loose. b. Check whether the inlet and outlet holes of the energy storage cabinet are sealed completely.	One year
Ground	Check the following items and perform maintenance a. Check whether the ground wire is connected reliably b. Check whether the ground wire resistance meets the specification	One year
System status	Check the following items and perform maintenance a. Check whether there is excessive noise, jitter or other abnormal phenomena during the operation of the equipment b. Check whether the temperature and humidity of the equipment are within the normal range. c. Check whether the equipment is damaged, components are damaged, or rusted. d. Check whether the air outlet of the device is blocked	Two years

### Notice:

The table only shows the recommended routine maintenance intervals for the product. The actual maintenance cycle should be determined based on the specific installation environment of the product. Factors such as the scale of the power station, its location, and the on-site environment will all affect the maintenance cycle of the product. If the operating environment is windy and sandy, the maintenance cycle needs to be shortened and the maintenance frequency increased.

## 7.5 System cleaning

Since the energy storage cabinet operates outdoors for a long time, regular cleaning is necessary. Regular cleaning can maintain the appearance of the equipment, reduce corrosion of the casing, improve the heat dissipation efficiency of the equipment, thereby extending the service life of the equipment and improving system operating efficiency.

### 1. Clean the outside of the energy storage cabinet

The exterior of the energy storage cabinet can be sprayed with cleaning agent and then wiped with a rag to prevent water stains from flowing into the equipment from the air outlet during cleaning.

### 2. Clean the inside of the energy storage cabinet

Inside the energy storage cabinet, use a vacuum cleaner to absorb dust.

### 3. Door lock and hinge inspection

Check whether the door locks, hinges, etc. of the energy storage cabinet can be used normally and whether there are any jams, etc.

### 4. Inspection of sealing condition

A good seal is an important guarantee for effectively preventing water seepage inside the energy storage cabinet. It should be carefully checked. If the seal is damaged, please deal with it immediately.

## 7.6 Touch-up operation instructions

- Only when the outer surface is dirty

1. Use a rag dampened with water or 97% alcohol to clean.

- When the topcoat is damaged

1. Use sandpaper to smooth the surface of the damaged area.

2. Use 97% alcohol to clean the surface.

3. After waiting for the surface to dry, repaint the damaged parts and make the repaint as even and beautiful as possible.

- When the paint surface is damaged and leaks out of the base material

1. Use sandpaper to smooth the surface of the damaged area.

2. Use 97% alcohol to clean the surface.

3. After the surface is dry, spray zinc-rich primer on the damaged area.

4. After the primer is dry, reapply the topcoat and make the repaint as even and beautiful as possible.

Dear Mr. \_\_\_\_\_/Company:

Thank you for purchasing and using our company's products!

Since the product you purchased is a technical product, you need to use it strictly in accordance with the operating instructions in the product user manual. Please read and understand the product user manual carefully before operating the product.

If the operating instructions shown in the manual are violated, the product may suffer serious consequences such as damage, loss of control, smoke, fire, etc.

beg to be excused!

Maitian Energy Co., Ltd.

date: \_\_\_\_\_